

G570 A/B

KRUIPHOL
TUNNEL À GRIMPER
CRAWLING HOLE
KRIECHTUNNEL
BUCO PER GATTONARE
TÚNEL DE GATEO

Montagehandleiding Notice de montage Assembling manual Montageanleitung Instrucciones para el montaje Istruzioni di installazione

Leeftijd:
Age: 2-8
Age group:
Alter:
Edad:
Età:

EUROPLAY nv
Eegene 9
B-9200 DENDERMONDE
tel. 32.52.22 66 22
fax.32.52.22 67 22
www.europlay.eu

Dat.: 16/04/2015
Page: 1/4

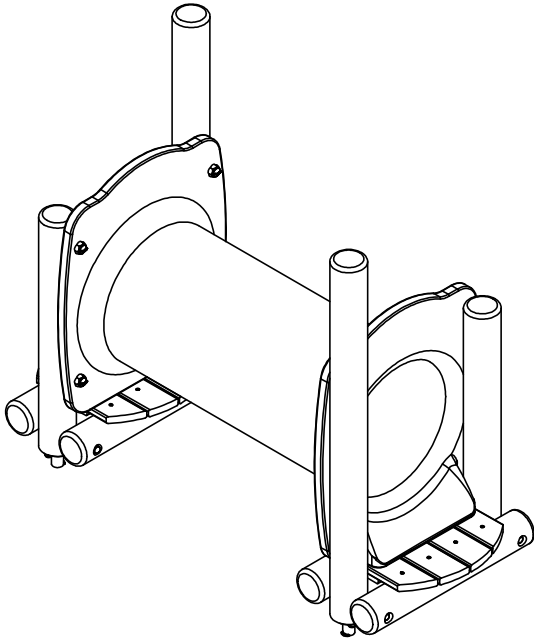

VALHOOGTE / HAUTEUR DE CHUTE /
FALL HEIGHT / FALLHÖHE/
ALTURA DE CAÍDA / ALTEZZA DI CADUTA

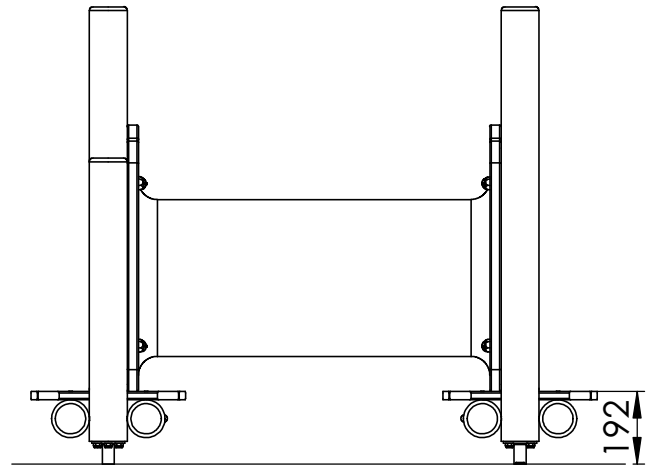



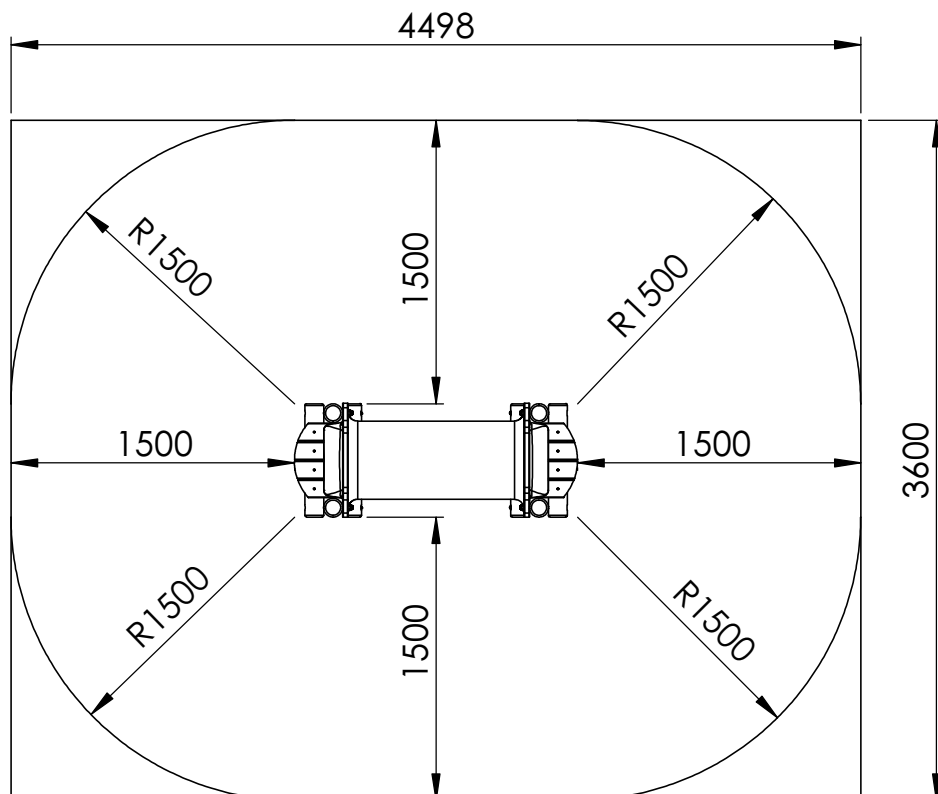





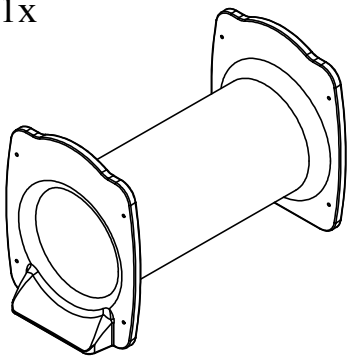
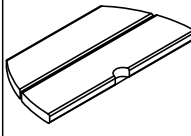
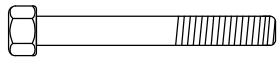
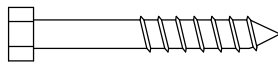

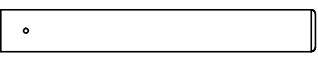
VEILIGHEIDSAFSTAND / ESPACE DE CHUTE / SAFETY AREA /
SICHERHEITSAFSTAND / ZONA DE SEGURIDAD / DISTANZA DI SICUREZZA

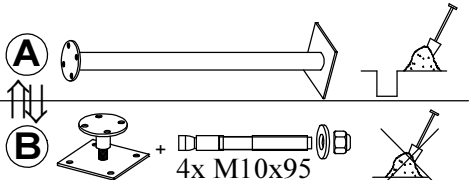

AFMETINGEN
DIMENSIONS
MASSE
DIMENSIONES
DIMENSIONI
L: 1,5m
H: 1,2m
Br: 0,6m

Benodigdheden - Liste des pièces - Materials - Benötigtes - Accesorios - Requisiti

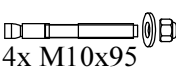
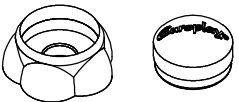
1x		4x		4x		M10x280
				8x		M10x70
				8x		M10
2x	 G570-H-V1 (750xØ100)			4x		M10
2x	 G570-H-V2 (1150xØ100)			16x		Ø4,5x50
4x	 G570-H-H1 (600xØ100)			4x		M10
4x	 G570-H-H1 (600xØ100) A:  B:  +  4x M10x95			8x		

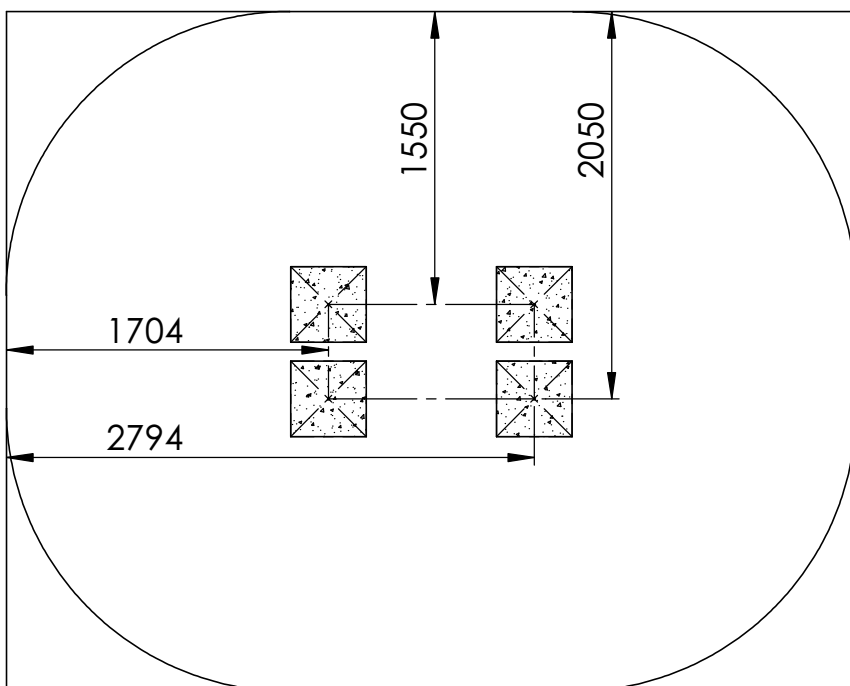

G570-A

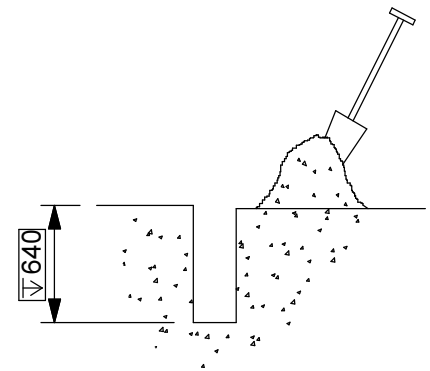

G570-B

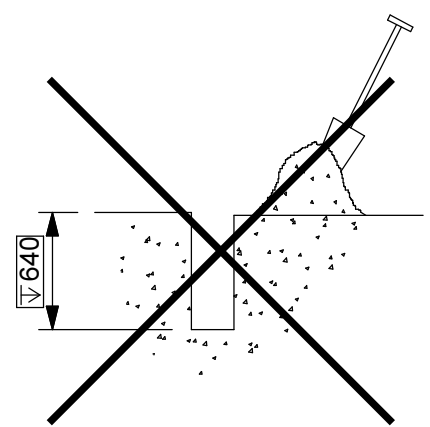

① **G570-A**

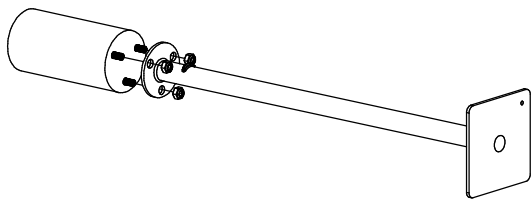

① **G570-B**

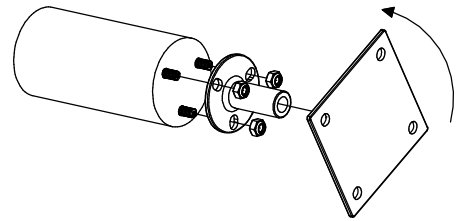

②

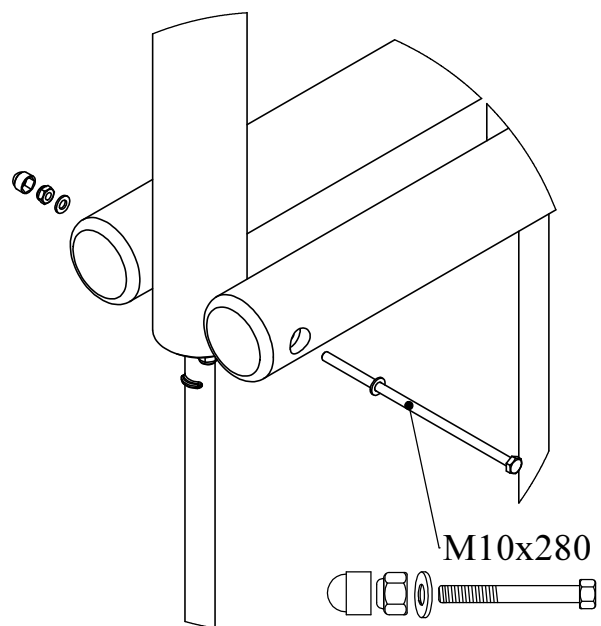
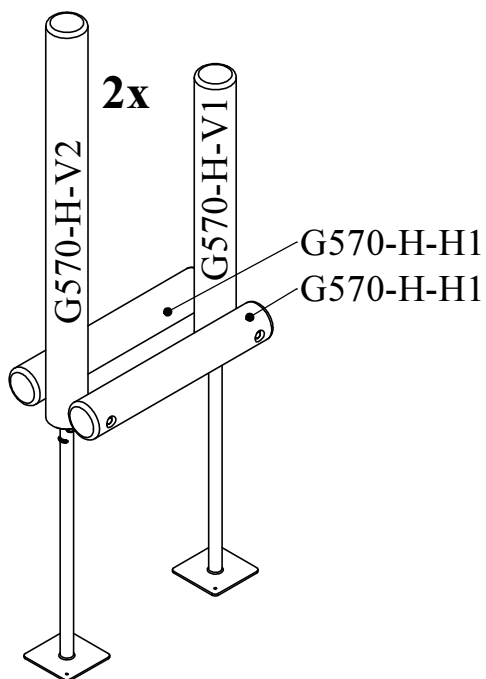

③

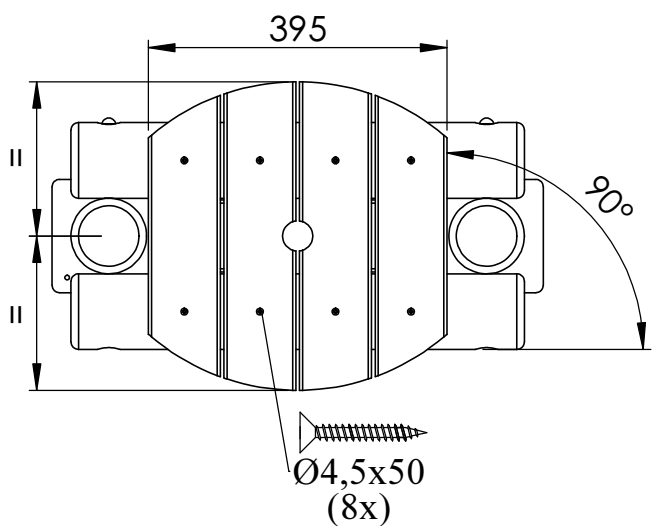
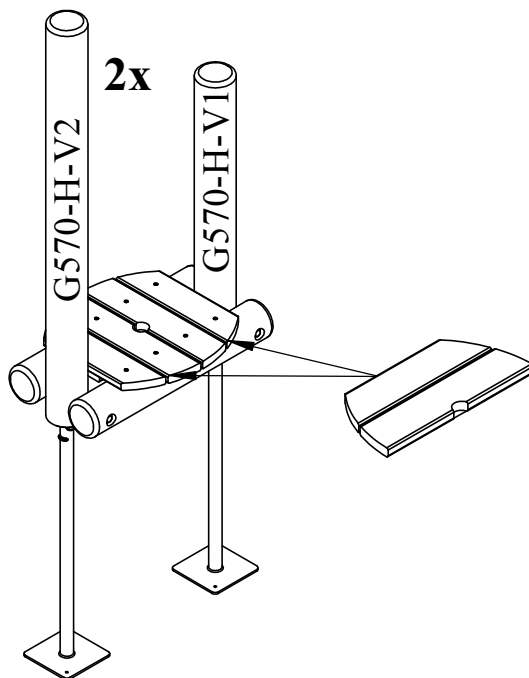

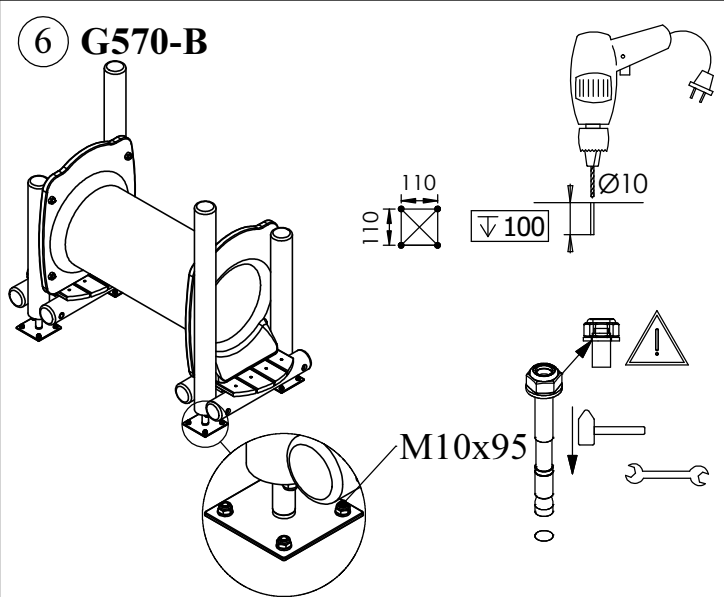
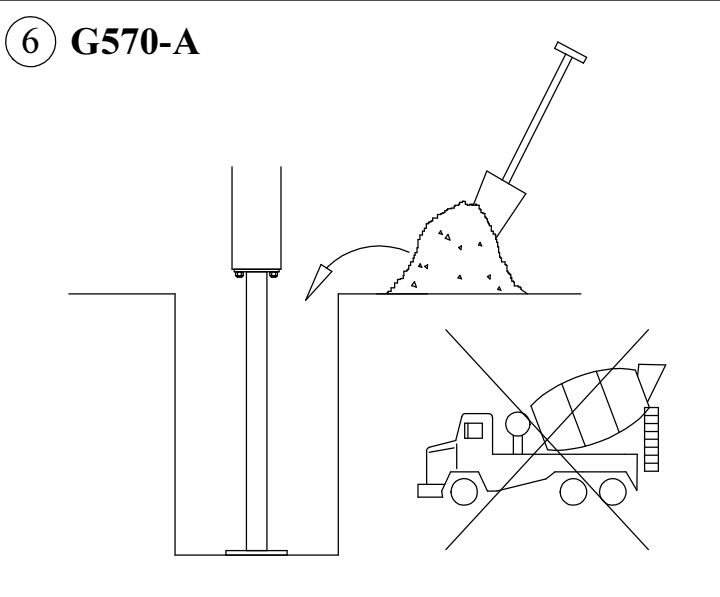
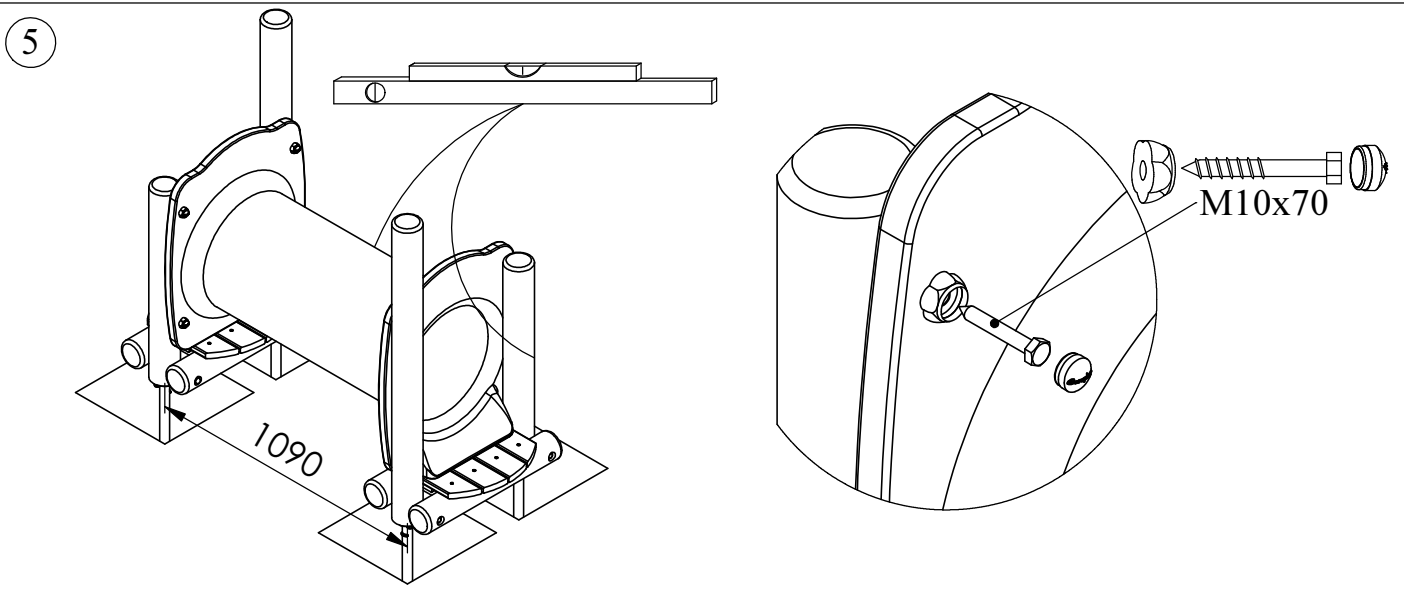
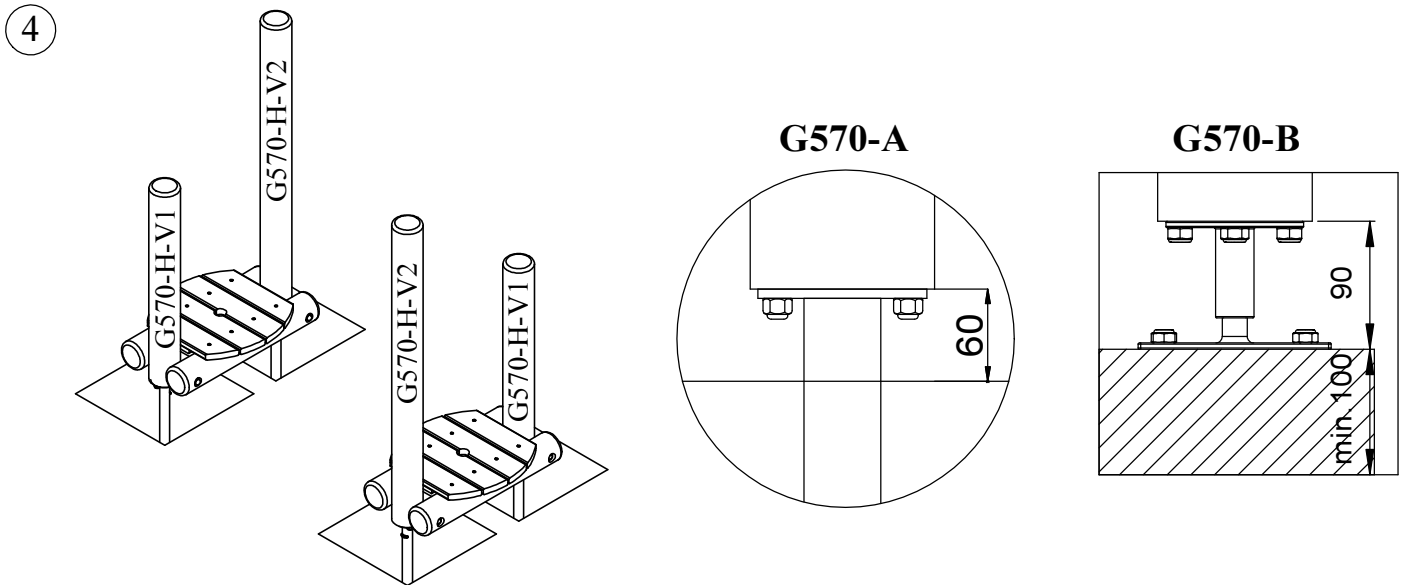

7

Bij droog weer moeten alle bouten en schroeven opnieuw aangespannen worden.
Par temps sec il faut resserrer régulièrement toute la visserie.
By dry and warm weather check the tightness of all bolts and screws.
Bei trockenem Wetter müssen alle Schrauben und Bolzen aufs neue angespannt werden.
Para el tiempo seco, se necesita cerrar o ajustar los tornillos y tuercas.
Con tempo asciutto, tutti i bulloni e le viti devono essere avvitate nuovamente.